

Tylaska SS-L Plunger Pin Lifting Hooks

SS-L Series Stainless Steel Plunger Pin Hooks

- Meets CE requirements for approval as a lifting accessory.
- 100% stainless steel components.
- All load-bearing components are fully traceable.
- 17-4 PH stainless steel components are heat treated to a specific condition to ensure high strength, moderate ductility, and a high resistance to corrosion cracking.
- Plunger pin style lock and self-closing latch design ensures hook will not open under load.
- Every hook is proof tested to 4.5 times the Working Load Limit.
- Design fatigue tested to exceed 20,000 cycles at three times the Working Load Limit.
- Can be used for man-riding applications when incorporated into a launching appliance that meets the requirements of Red Ensign Group Yacht Code.



Model	Part Number	Working Load Limit (metric ton)		Dimensions (mm)								Weight (kg)
		8:1*	10:1*	A	B	C	D	E	F	G	H	
SS20L-S	TY2020L-S	2.0	1.6	30	133	19	75	19	25	32	37	1.1
SS20L-C	TY2020L-C	2.0	1.6	30	124	19	75	18	25	32	37	1.2
SS40L-S	TY2040L	5.0	4.0	47.2	228.1	30.5	117	29	36	50	58	4.0

*The 8:1 design factor WLL is for general lifting applications. For man-riding applications, the 10:1 WLL should be followed.

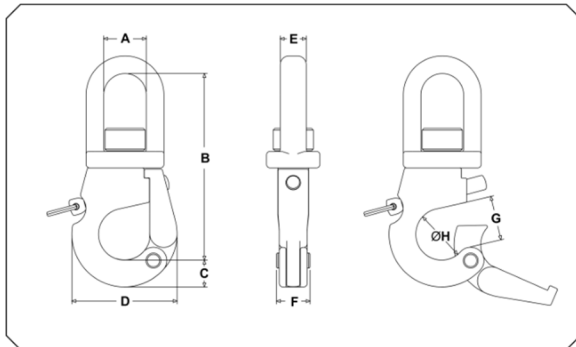

Standard Bail "S" Model

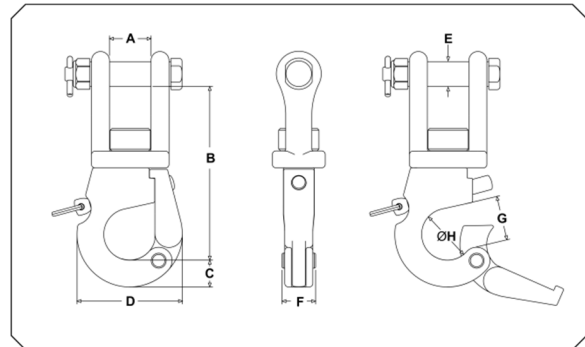

Clevis Bail "C" Model

⚠ WARNING ⚠

LOAD DISENGAGEMENT CAN RESULT IN SERIOUS INJURY OR DEATH

- Read and understand instructions before using hook.
- Never exceed the specified Working Load Limit (WLL).
- Never use tip of hook for lifting.
- Never use a damaged or excessively worn hook.
- Never use a hook with missing or illegible manufacturer or rated load identification.
- Always comply with local and Federal regulations.
- Always ensure latch is closed and locked with the plunger pin fully engaged before loading hook.
- Keep hands and body from between hook and load.
- Never use hook in temperatures in excess of 400°F (204°C) or below -40°F (-40°C).

Instructions for Use

- All hooks shall be inspected both frequently and periodically for proper latch and plunger pin functionality, unauthorized alterations, wear, cracks, nicks, gouges, corrosion, and deformation by a qualified person in accordance with ASME B30.10.
- Never modify or repair hook. Contact Tylaska if repairs are needed.
- Remove hook from service if it is found to have any of the following defects:
 - Cracks or significant nicks or gouges
 - Excessive pitting or corrosion
 - Wear exceeding 10% of the original section dimension
 - Any visible twist or bend from the plane of the unbent hook
 - Any deformation that prevents the plunger pin from fully engaging the latch when closed.
 - Damaged or missing nut pin allowing for the nut to tighten or loosen freely.
 - Missing or illegible manufacturer identification or rated load identification
 - Inability of latch to lock closed
 - Evidence of excessive heat exposure or unauthorized welding
- Evidence of unauthorized alterations such as drilling, machining, grinding or other modifications Load must be centered on the saddle of the hook. (Figure 1a)
- No more than two (2) slings shall be placed on the hook saddle. The angle from vertical to the leg nearest the hook tip shall not be greater than 45 degrees and the included angle between the legs shall not exceed 90 degrees. (Figure 1b)
- The hook latch must be closed and locked before loading. The plunger pin tip must stick out of latch. (Figure 2a) Never load a hook with a recessed plunger pin. (Figure 2b)
- Never load hook to the side, back, or on the hook tip. (Figure 3)
- Never expose hook to highly alkaline, acidic, or excessively hot (>400°F) environments.
- Never swivel the bail while under load. The swivel function of the bail is intended for unloaded rotation only.
- Understand applicable regulations and safety standards before using hook. OSHA standard 1910.184 describes the safe operating practices, inspection requirements, product identification, and use limitations of slings. Additional information can be found in ASME standards B30.9 – *Slings*, B30.10 – *Hooks*, B30.16 – *Overhead Hoists (Underhung)*, B30.21 – *Manually Lever Operated Hoists*, and B30.5 – *Mobile and Locomotive Cranes*. Refer to Red Ensign Group Yacht Code when incorporating hook into launching appliance.

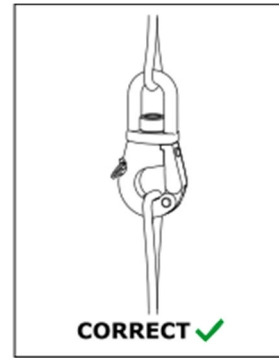

Figure 1a

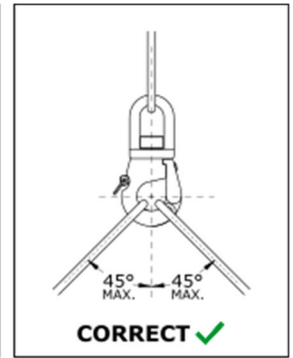

Figure 1b

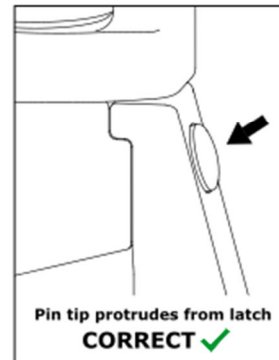

Figure 2a

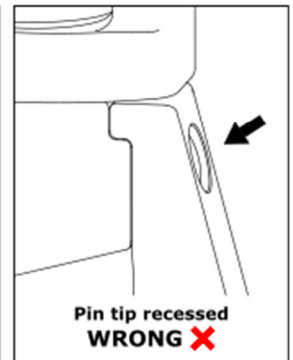

Figure 2b

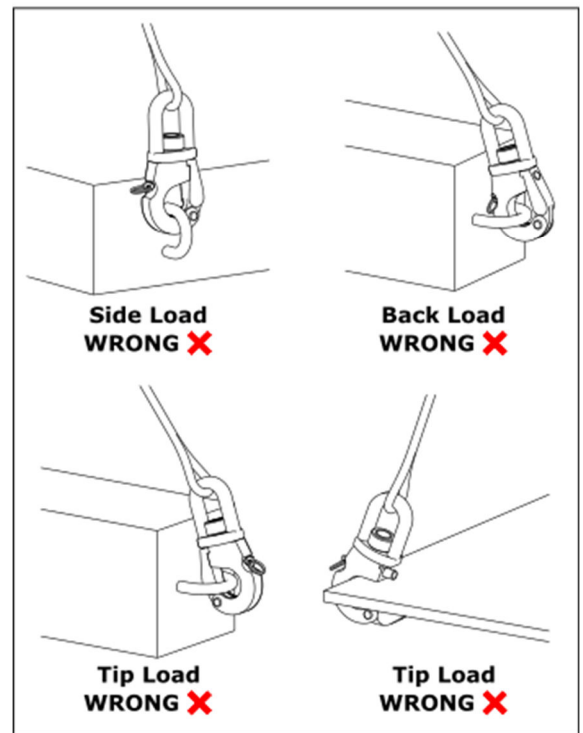
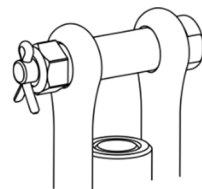

Figure 3

Additional Instructions for Clevis Bail Models

- Always ensure that the clevis pin is properly installed and secured with the supplied nut and cotter pin before loading the hook.
- Only use the supplied Tylaska clevis pin and nut. Contact Tylaska for replacement clevis pins, nuts, and cotter pins.
- Immediately replace cracked, worn, corroded, or otherwise damaged cotter pin.



Instructions for Use

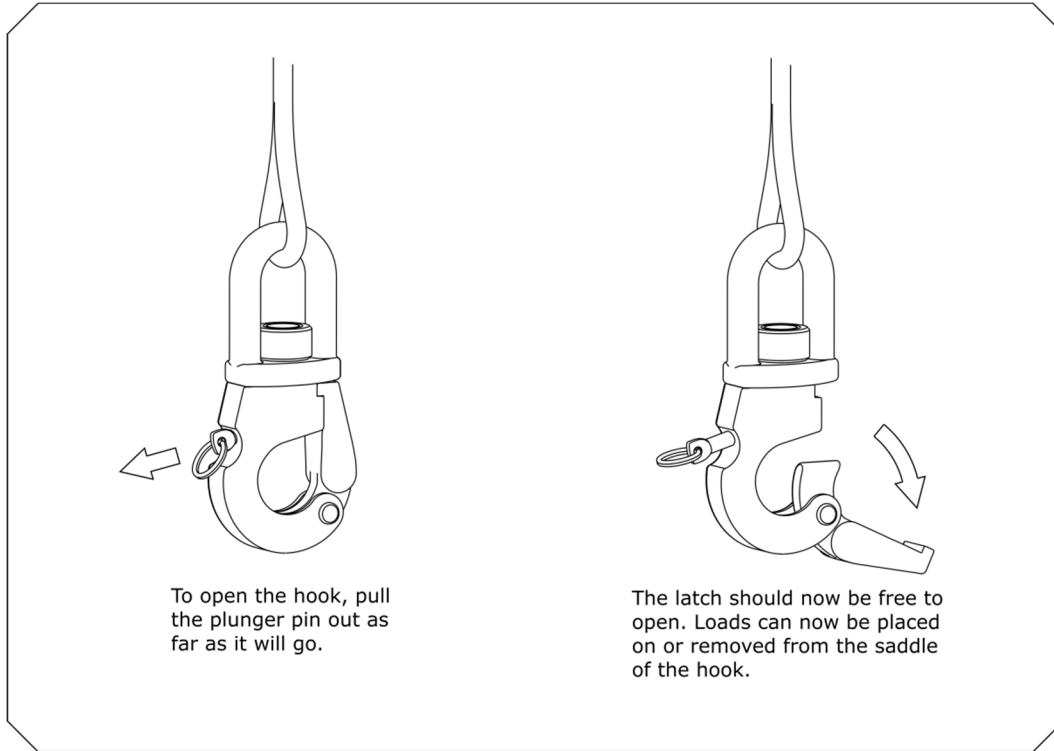

Opening Hook

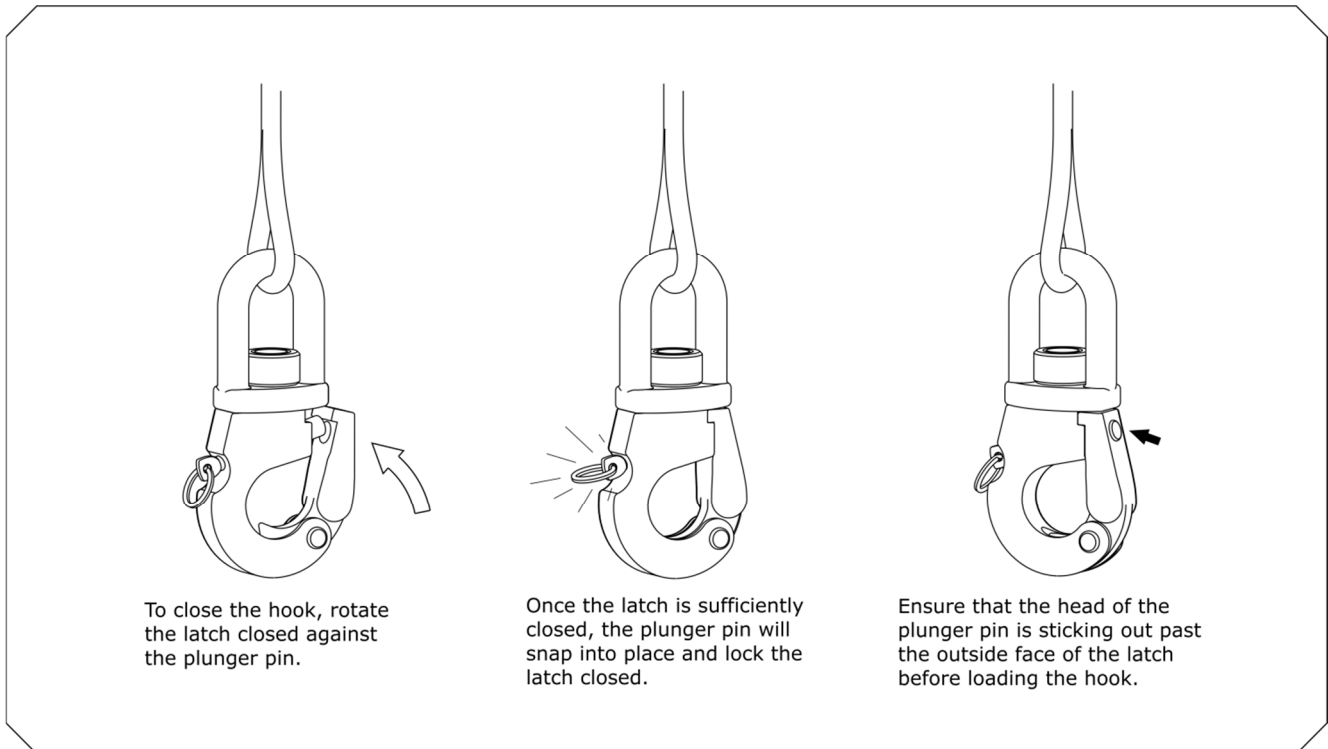

Closing and Locking Hook